

The  
*“Over-Engineered”*  
Spherical  
Turning Tool

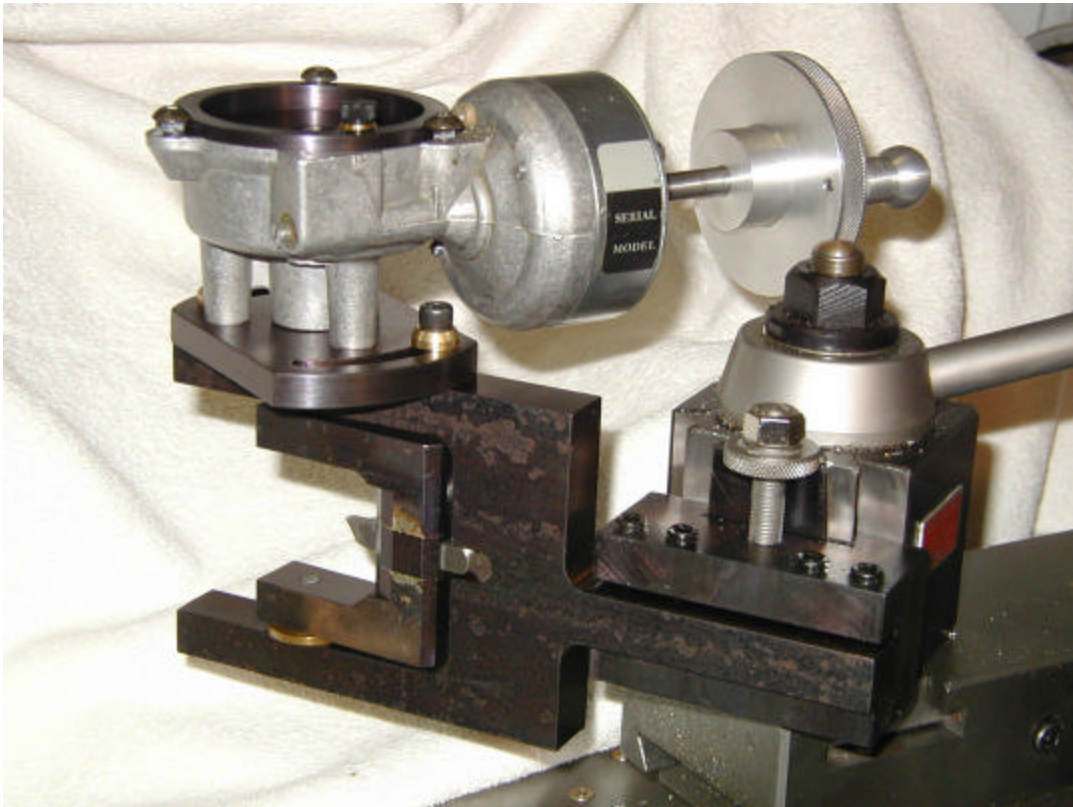

Designed/Built by: Reed M. Streifthau  
Apr-May01, reed@xs11.com

**Introduction:** My need for a ball turning tool began with the desire to build a Quorn Tool and Cutter Grinder. The Grinder requires 18 ball handles that could be bought, but then it would not be quite the same. Thus the quest to build a Spherical Turning Tool.

Searching the Web resulted in three different designs of shop and manufacture built tools. The fourth is a method of grinding the radius form cutter. I chose to design a swiveling yoke type. Jay Tackwood wrote up a design I used as a starting point. At the time of this writing (Jun01), it could be found at

<http://www.metalwebnews.com/howto/baltool/balltool.html>. The tool in this paper has a range of 0-1½ diameter ball. My working drawings are at the end of the paper.

The major pieces are Frame Yoke, Swiveling Yoke, Gearbox, and Micrometer Setting Tool.

**Layout & Rough cut:** Using a piece of ¾ x 4” hot roll (one should consider buying a piece of CRS for a better finish), I laid out and cut the pieces as per the picture below. Note the drilled holes to provide a radius to facilitate sawing around the corners.

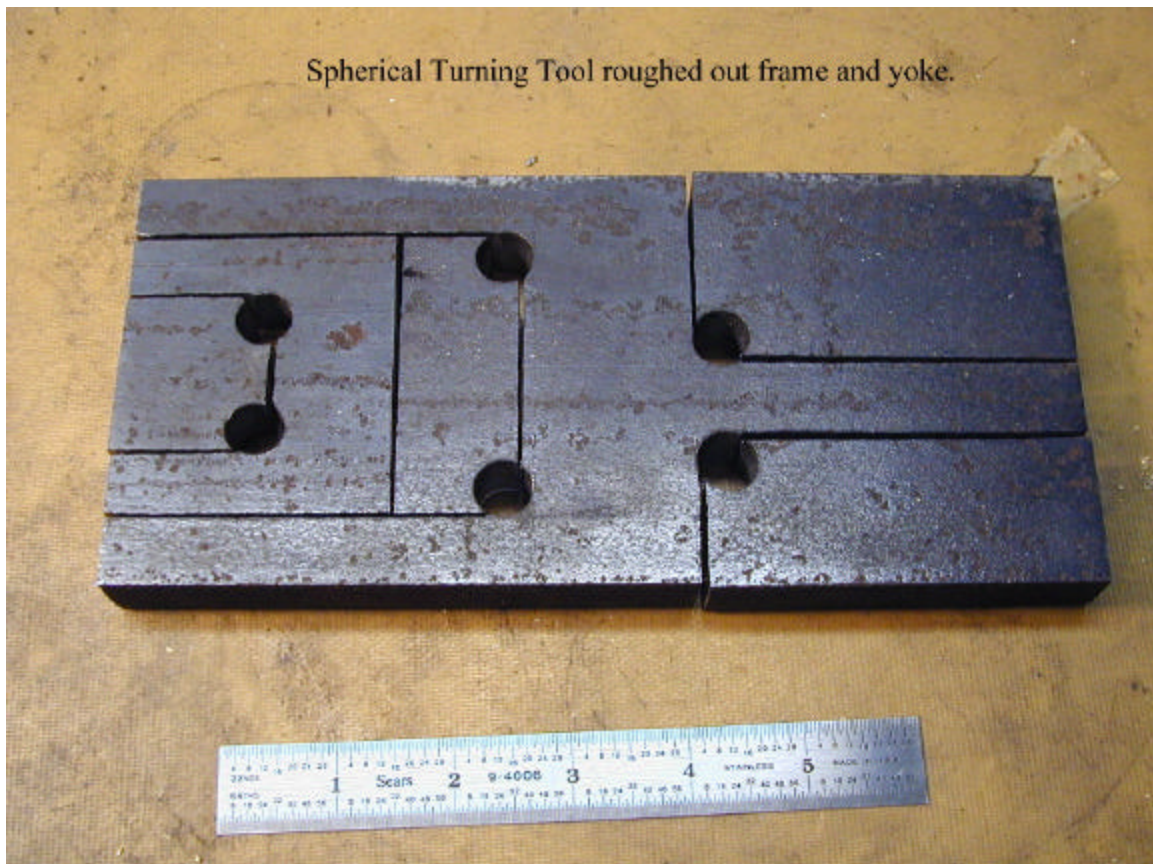

Three pieces were used, picture below. The two yoke pieces were milled to spec cleaning up all edges except the mill scale. The clearance slot in the Frame Yoke was milled later. Additional clearance milling (beveling) on the Swiveling Yoke was preformed to increase the swiveling range.

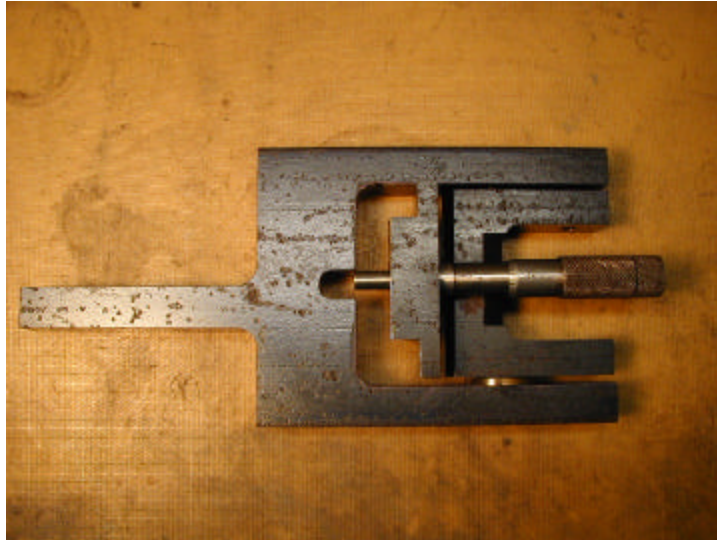

**Machining the Yokes' Holes:** The bushing, setscrew, and pivot holes were located via the mill table and should be drilled/reamed before turning the bushings. The bottom bushing provides the thrust surface for the downward cutting pressure and the top bushing is a simple cylinder. The bushings are turned and pressed in. The gap between the top of the Swiveling Yoke and the bottom of the Frame Yoke is insignificant and left alone. One could refine the design and eliminate the gap.

I was faced with an interesting decision when creating the cutter bit's square hole. Hand filing was too labor intensive for the resulting fit, and buying a square broach (and arbor) would defeat the idea of doing this "cheap". Of course, it could be sent out to a shop. Another idea is to drill the hole, grind a cutter bit with a single square corner, mount the bit and Swiveling Yoke on the lathe, and use the carriage as a shaper to slowly shave the four corners. That was too slow for me. The following pictures tell the story. The fill piece was silver brazed in place. A perfect 5/16 " square hole is shown below.

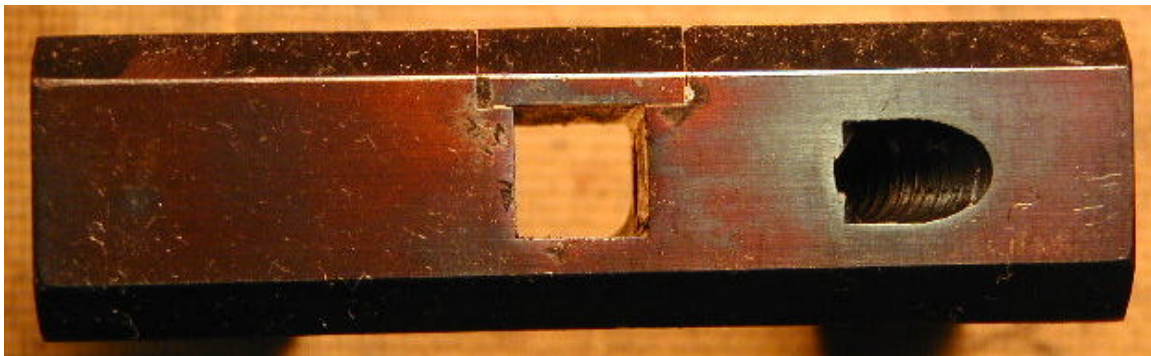

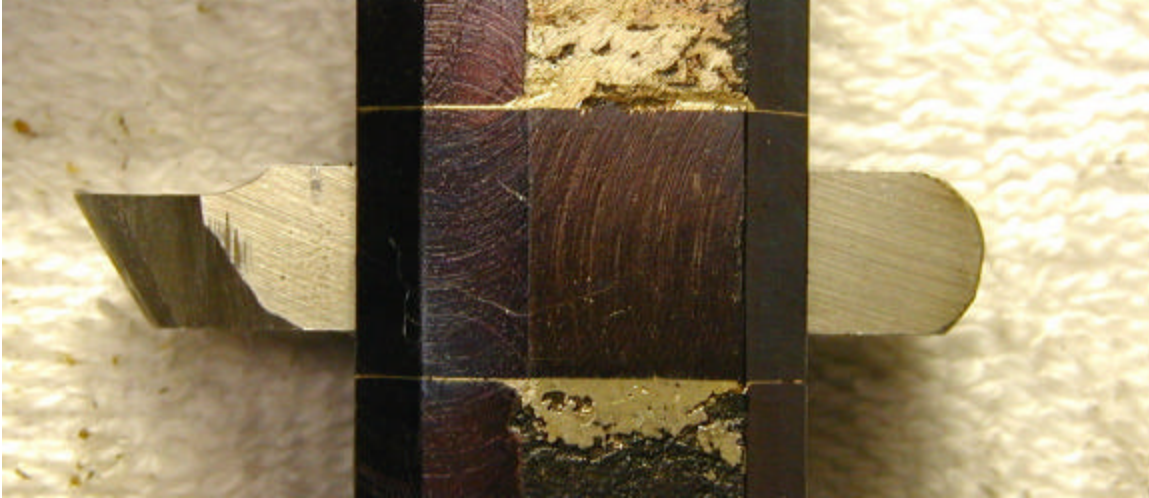

Next a hole for a  $\frac{1}{4}$  x 28 set screw was drilled and tapped. Note the thread portion is not tapped through (bottom tapped) in the drawing to ensure a non-threaded surface for the angled plug.

A piece of  $\frac{1}{4}$  x 2+” long drill rod is turned to .217 sufficiently along the length to slide completely into the  $\frac{1}{4}$  - 28 tap drill hole entering the  $\frac{5}{16}$  square hole. It is then carefully ground to the correct angle (hand fitted to the Swiveling Yoke). Remount on the lathe and part off. Following picture indicates the finished pieces.

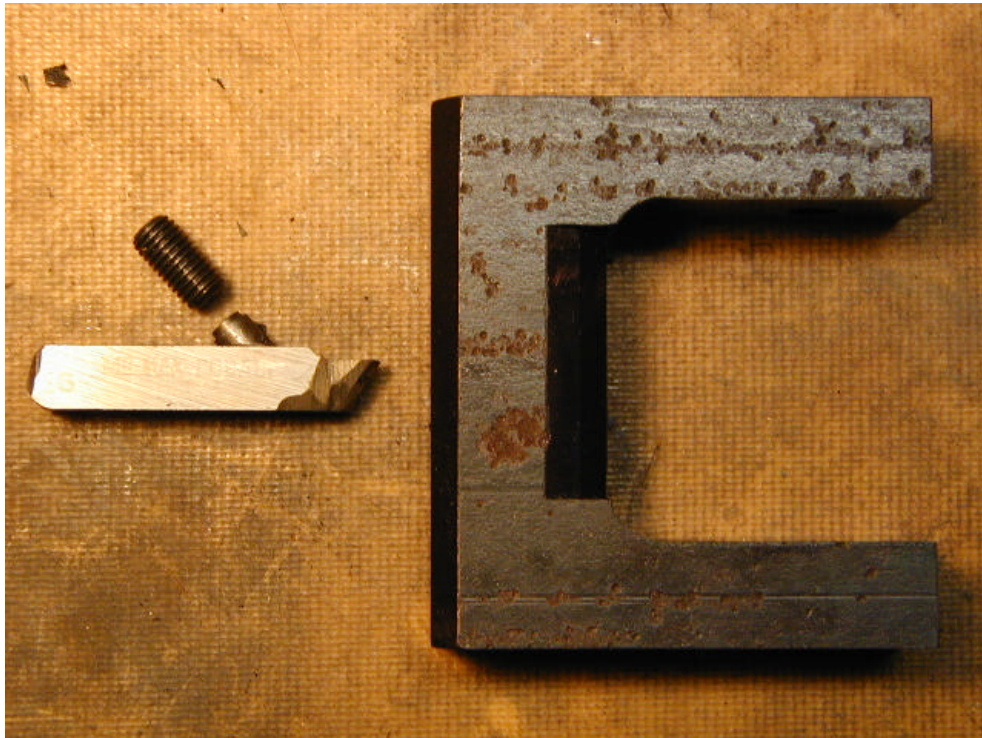

The clearance slot is located by inserting a new bit and scribing the top/bottom of the slot. Add an additional 50 thousandths for kicks and for any wear on the thrust bearing that will drop the cutting bit down.

With the addition of ¼“ drill rod, pivots for the top/bottom and a swiveling lever, this tool could be assembled to turn balls. However, it would not yet be sufficiently over-engineered.

**Worm Gearbox:** The rest of the parts depend on what is procured for a gearbox. I didn't include drawings for gearbox related pieces. My gearbox, shown with the winding discarded and spacer cut, was a DC gearhead motor from a piece of scrapped hospital equipment.

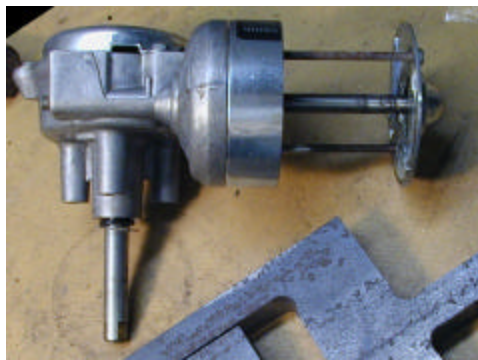

Modifications required depend on the gearbox. This one required:

- Electrical parts discarded including magnets
- Motor housing cut to make spacer to move outboard bearing toward gear housing
- Outboard bell housing drilled to allow motor shaft to slide through
- Thrust ring for outboard bearing surface
- Output shaft turned down to fit the Spherical Turning Tool
- Gearbox mounts and output shaft bearing machined to fit Tool
- Gearbox machined to accept adjustable stop plate
- Gear for the stop post drilled and tapped

When machining the gearbox, always remember the point of reference is the output shaft. The die cast surfaces were not as parallel and square to each other as one would like.

One needs to make a handle to turn the input shaft. I used a piece of scrap 1” aluminum plate. It was turned to a nominal 3” with a knurl strip. The knob was the first piece turned using the Spherical Turning Tool. A shoulder bolt attaches the knob to the handwheel.

I made the gearbox mounting plate with the over-engineered feature of 60 degree rotation about the vertical axis. This was to allow some adjustment for line of sight to the workpiece. Since dimensions will vary, here are pictures of the top and bottom views.

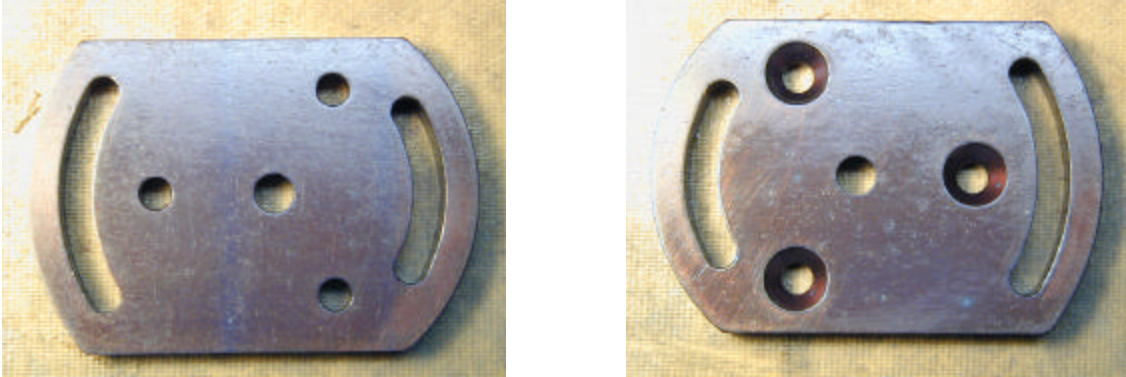

An adjustable stop plate was fabricated to mount on the top of the gearbox, as one can never have enough features. The following are pictures of the top and bottom views of the adjustable stop plate.

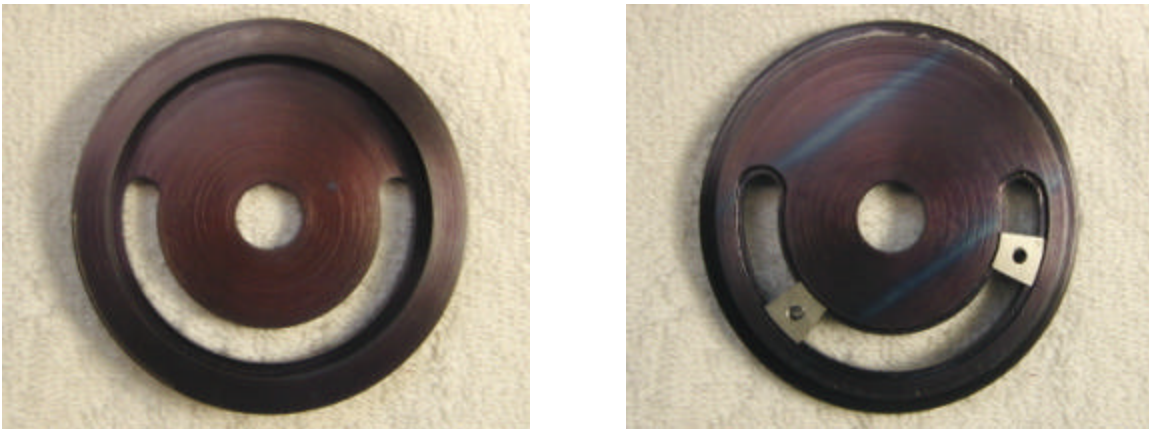

The T-nuts were milled out with the correct radius for the slot. They would probably be fine with parallel sides, but they fit and slide quite well with the mating curved sides.

Below are the adjustable stops and gearbox mounting plate setscrews with their respective thrust washers. I had some Shear-lock knobs left over from a “Zero-it” indicator project; those were used for the adjustable stop setscrews knobs.

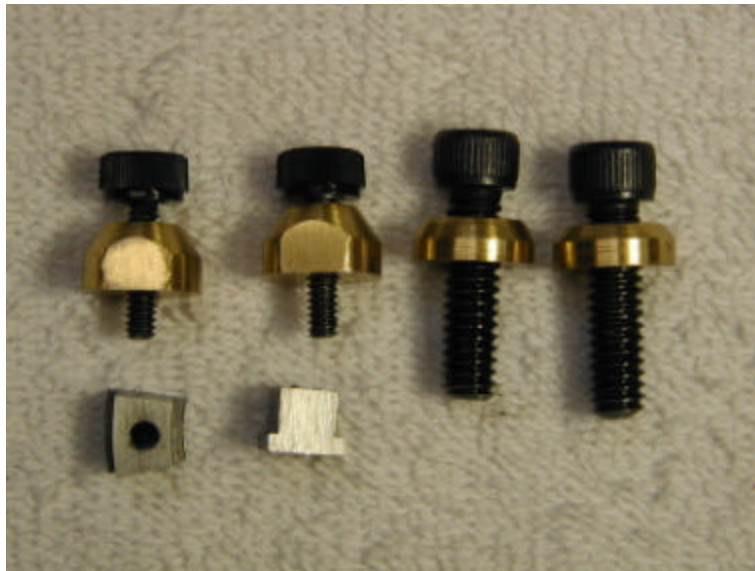

Below is a picture of the turned down output shaft with gear. The stop for the adjustable stops is installed with Loctite. A flat was milled for the Swiveling Yoke’s setscrew.

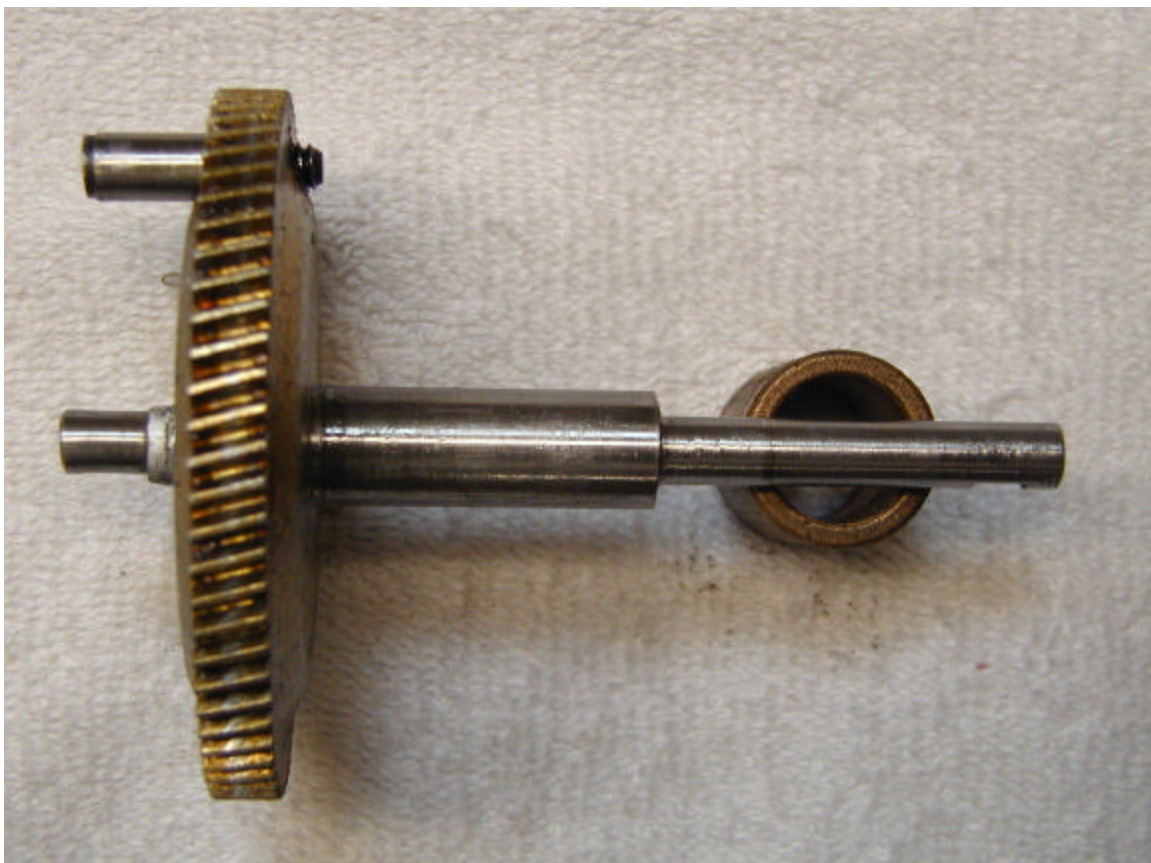

The assembled adjustable stop plate picture is below. I made two adjustable stops. In practice, only one is needed. The plate rotates and sets the starting point at the end of the stop slot. The ending point is then set with the adjustable stop.

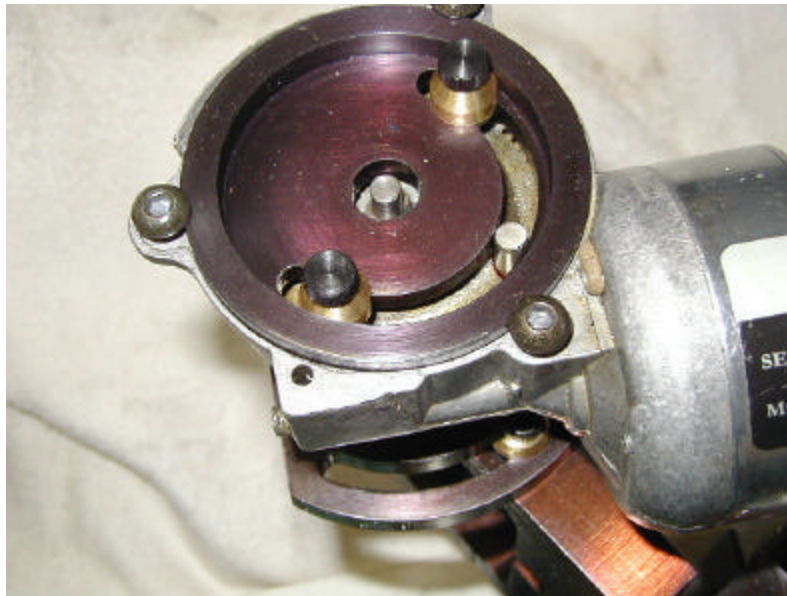

Note the stop plate is machined to the outside diameter to accommodate the use of cap screws to lock the plate down. The original tapped holes were just slightly in the wrong place. The new tap drill diameter holes were located with a rotary table, milled with a boring head, and tapped. An alternative would be to change the design of the outer edge of the adjustable stop plate to fit the existing holes.

The last part made was the micrometer bit setting tool. The micrometer head is from a used micrometer that had been replaced, but not tossed out (packratisitis). The housing material was cutout at the beginning with the two yokes. The pictures show the micrometer bit setting tool and how it is used.

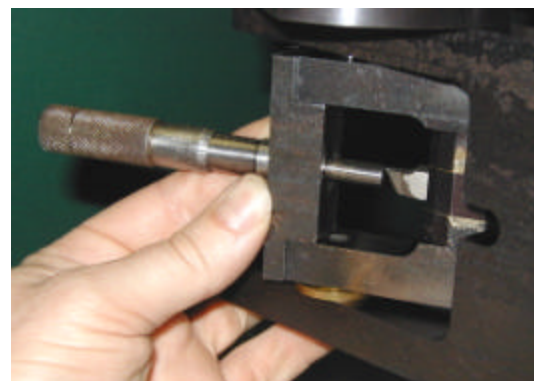
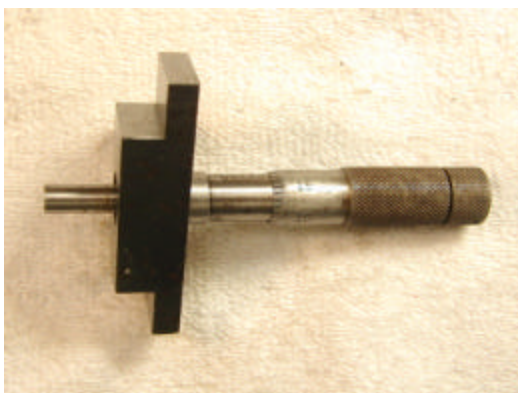

The micrometer head was turned down only as much as needed and the hole in the housing is bored to the micrometer head diameter plus 0.002" for the Loctite.

The micrometer setting takes only minor math. The bit setting is in radius so one subtracts the ball radius from 1 and that is the setting on the micrometer. Simply dial in the setting, hold it in place on the Swiveling Yoke, slide the cutting bit to the micrometer anvil, and tighten the setscrew. This is where one appreciates the time spent on the angled plug. The bit does not move when being tightened.

Working Drawings

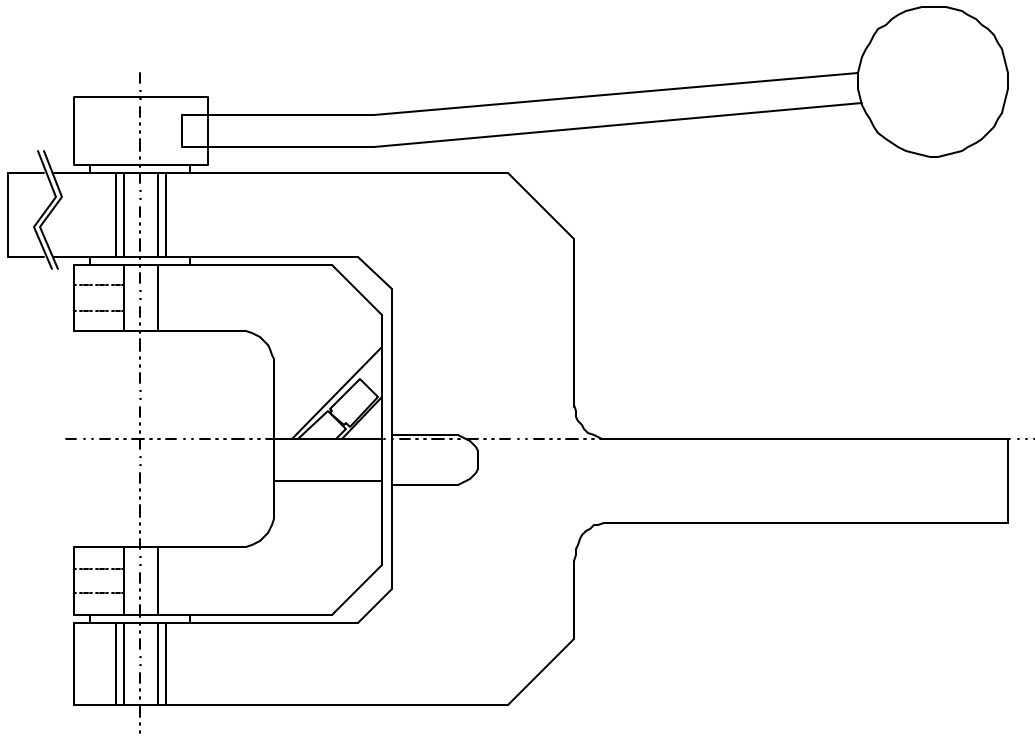

Figure 1, Tool with turning handle(handle never built)

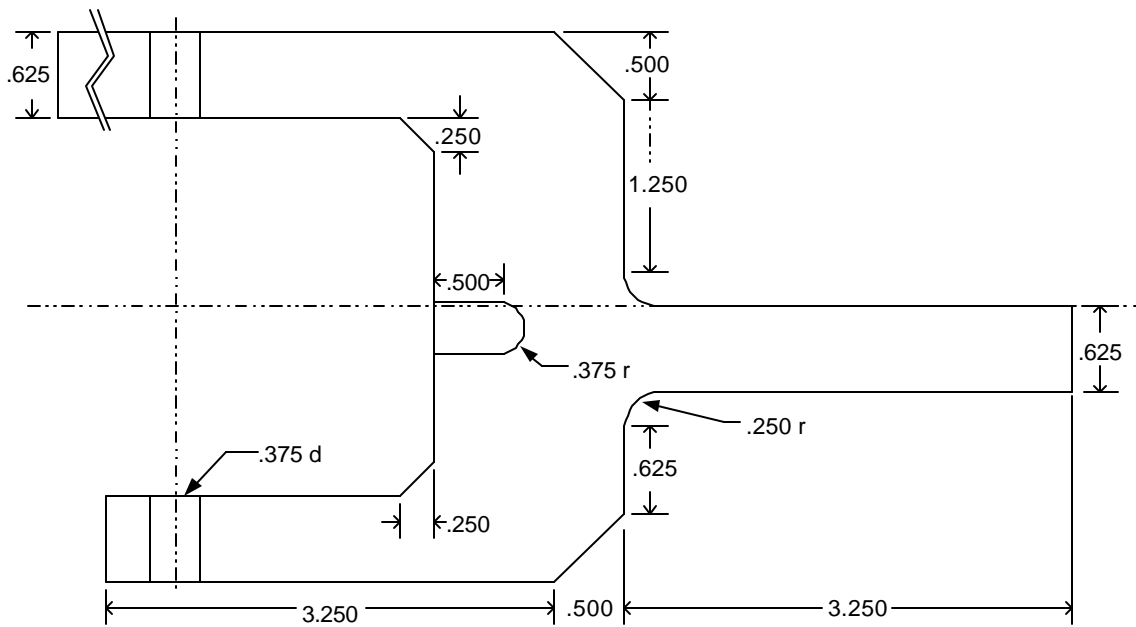
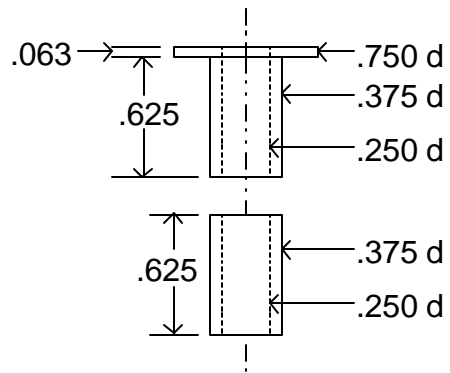
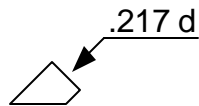

Figure 2, Frame Yoke



**Figure 3, Brass Bushings**



**Figure 4, Angled Plug (bit setscrew)**

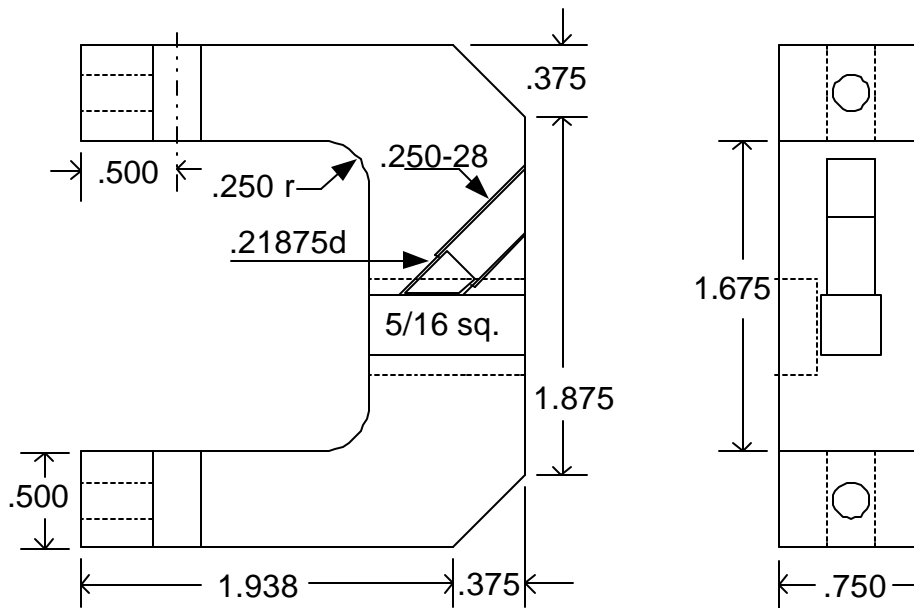

**Figure 5, Swiveling Yoke**

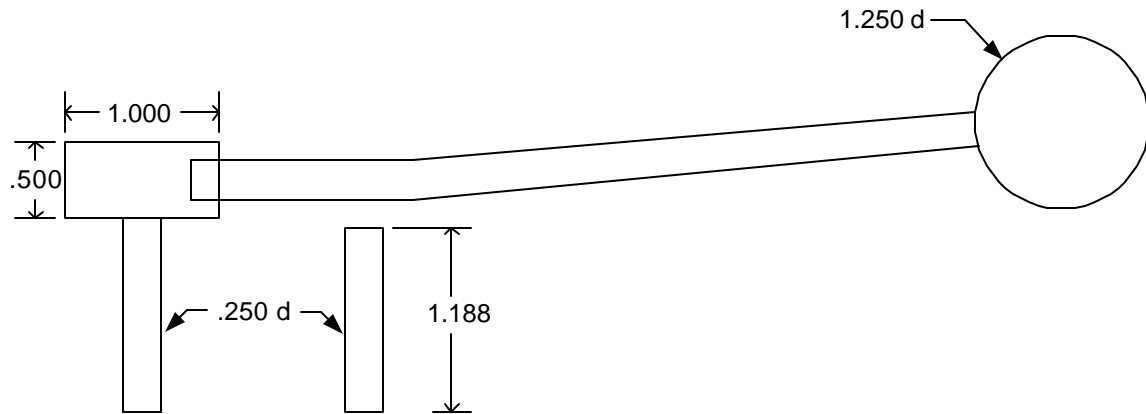

**Figure 7, Turning Handle with Top and Bottom Pivot**

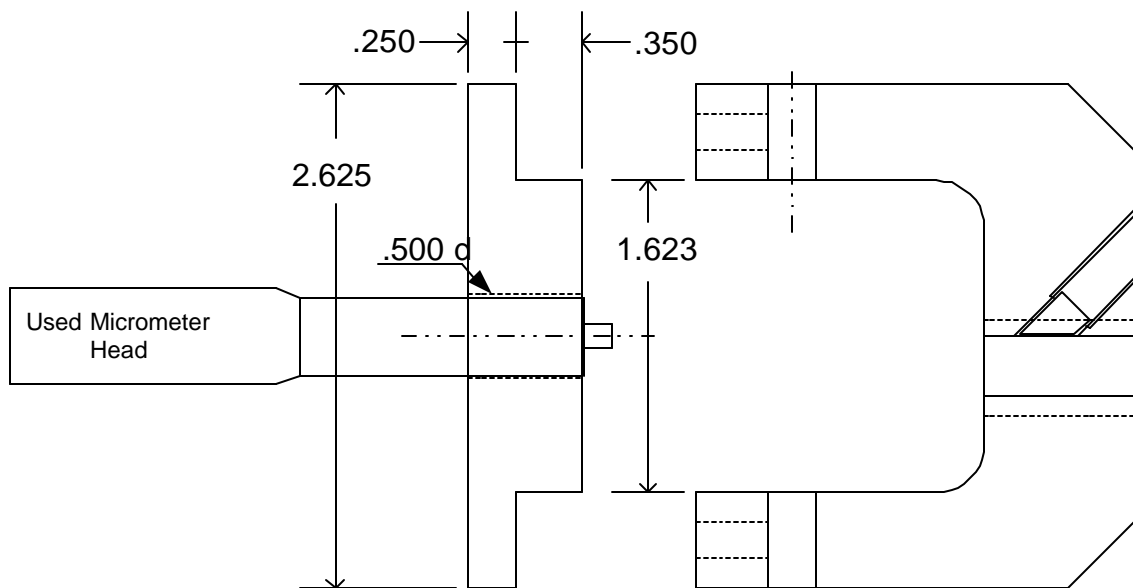

**Figure 8, Micrometer Bit Setting Tool**